

3 YEAR WARRANTY

High Power Flood Light

MaxBrite High Power LED Flood Light Series is designed as a replacement of traditional halogen lamps. Its high-class aluminum alloy casing ensures sufficient heat dissipation and invites an excellent luxurious environment.

- High Quality LED Light Source (Ultra Bright Grade)
- Superior Color Temperature Nature White 5000k
- High-Class Alum. Alloy Case (excellent heat dissipation)
- Light Output Equivalent to 250 Watts Halogen light
- 50,000 hours lifespan
- No UV or IR Radiation

Applications

- Decorate lightings
- Landscape Lighting
- Parking Lighting
- General lightings



High Power Floodlight 40 Watts Natural White 5000K

★ **Specification**

CCT (Kelvin)	Natural White 5000k
Lumen Flux (lm)	4000 lm
Operating Voltage	120-240V AC (50-60 Hz)
Consumption	40 Watt
Working Current	350mA
LED Lamp	Bridgelux
LED Quantity	1
Viewing Angle	120°

★ **Environmental**

Operating Temperature	-40°c to +50°c
Storage Temperature	-40°c to +85°c
Rating	IP 65 (for indoor use only)
Case Housing	Aluminum Alloy
Base Holder	Swivel Bracket
Wire Connection	Hardwire
Dimensions	14-1/2" x 11-1/2" x 8-13/16" (L x W x D)
Weight	20.94 lbs.
Package	1 per carton

★ **Mechanical**

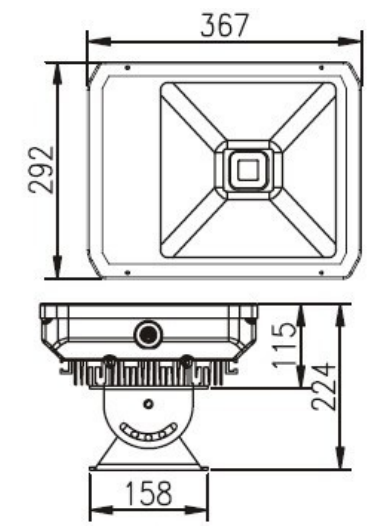

*CRI (Color Rendering Index) for white product types is 70 / *Luminous Flux measuring equipment is CAS140B
 *Viewing angle is the off axis angle from lamp centerline where the luminous intensity is half of the peak value / *CCT 5% tester tolerance
 *Dominant wavelength is derived from the CIE 1931 Chromaticity diagram and represents the perceived color
 *Color temperature for white is strictly controlled by bin rank system and it consists of three ranks which should not be used simultaneously.

